

Specifications:

Housing: LCP UL94-V0 Color: Nature
 Cove: LCP UL94-V0 Color: Black
 Contact: Phosphor Bronze
 Operating Voltage: 50V AC/DC
 Current Rating: 0.5A AC/DC
 Withstand Voltage: 250V AC/Minute
 Contact Resistance: $\leq 20m\Omega$
 Insulation resistance: $\geq 100M\Omega$
 Operating Temperature: $-25^{\circ}C \sim +85^{\circ}C$

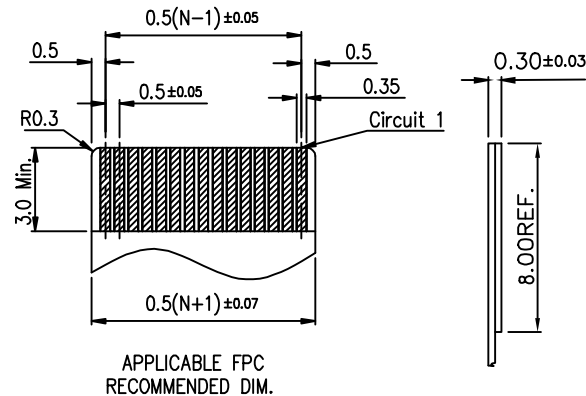
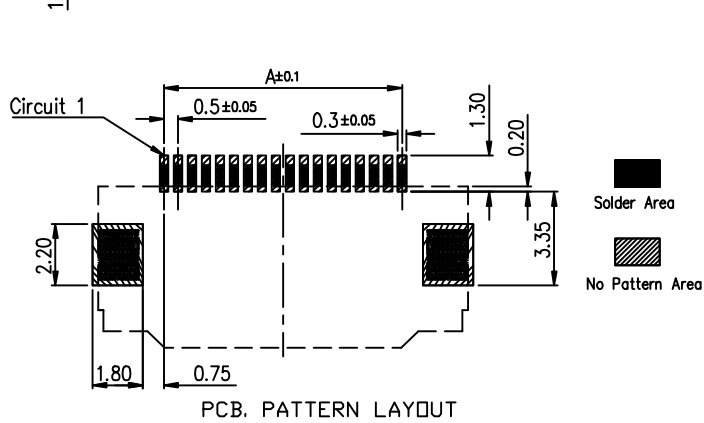
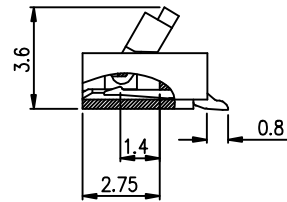
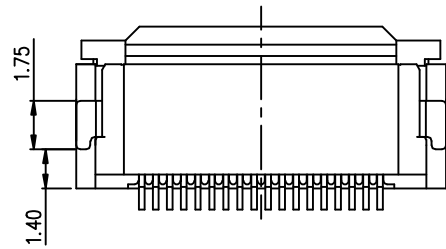
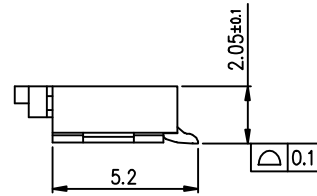
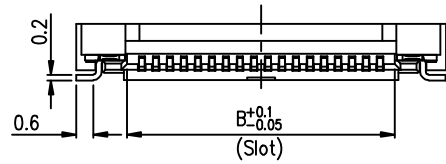

CKT	Dim A	Dim B	Dim C	CKT	Dim A	Dim B	Dim C
4	1.50	2.56	6.2	33	16.00	17.06	20.7
5	2.00	3.06	6.7	34	16.50	17.56	21.2
6	2.50	3.56	7.2	35	17.00	18.06	21.7
7	3.00	4.06	7.7	36	17.50	18.56	22.2
8	3.50	4.56	8.2	37	18.00	19.06	22.7
9	4.00	5.06	8.7	38	18.50	19.56	23.2
10	4.50	5.56	9.2	39	19.00	20.06	23.7
11	5.00	6.06	9.7	40	19.50	20.56	24.2
12	5.50	6.56	10.2	41	20.00	21.06	24.7
13	6.00	7.06	10.7	42	20.50	21.56	25.2
14	6.50	7.56	11.2	43	21.00	22.06	25.7
15	7.00	8.06	11.7	44	21.50	22.56	26.2
16	7.50	8.56	12.2	45	22.00	23.06	26.7
17	8.00	9.06	12.7	46	22.50	23.56	27.2
18	8.50	9.56	13.2	47	23.00	24.06	27.7
19	9.00	10.06	13.7	48	23.50	24.56	28.2
20	9.50	10.56	14.2	49	24.00	25.06	28.7
21	10.00	11.06	14.7	50	24.50	25.56	29.2
22	10.50	11.56	15.2	51	25.00	26.06	29.7
23	11.00	12.06	15.7	52	25.50	26.56	30.2
24	11.50	12.56	16.2	53	26.00	27.06	30.7
25	12.00	13.06	16.7	54	26.50	27.56	31.2
26	12.50	13.56	17.2	55	27.00	28.06	31.7
27	13.00	14.06	17.7	56	27.50	28.56	32.2
28	13.50	14.56	18.2	57	28.00	29.06	32.7
29	14.00	15.06	18.7	58	28.50	29.56	33.2
30	14.50	15.56	19.2	59	29.00	30.06	33.7
31	15.00	16.06	19.7	60	29.50	30.56	34.2
32	15.50	16.56	20.2	61	30.00	31.06	34.7
				64	31.50	32.56	36.2

一般公差
 TOLERANCES
 X ±0.40 XX ±0.20
 X ±0.30 XXX ±0.10
 ANGLES ±2°

深圳市新世联电子有限公司

检验尺寸标示
 SYMBOLS \odot \ominus INDICATE CLASSIFICATION DIMENSION
 \odot MARK IS CRITICAL DIM.
 \ominus MARK IS MAJOR DIM.

表面处理 (FINISH)

比例 (SCALE) 1:1
 单位 (UNITS) mm

工程图号
 品名 FPC0.5mm -nP H2.0mm 翻盖下接
 标题 FPC0.5mm Pitch H2.0 Flip ZIF CONN
 制图 (DR)
 审核 (CHKD)
 核准 (APPD)
 张数 (SHEET) 1 OF 1
 SIZE A4
 REV 0

REV	修改摘要 REVISION DESCRIPTION	日期 DATE	签名 SIGNATURE
△	-	-	-